

E/SV Series Tantalum Chip Capacitors

■ FEATURES

- Lead-free Type. In conformity to RoHS.
- Offer a range of small, high-capacity models.
- Succeed to the latest technology plus outstanding performance.

■ DIMENSIONS [mm]

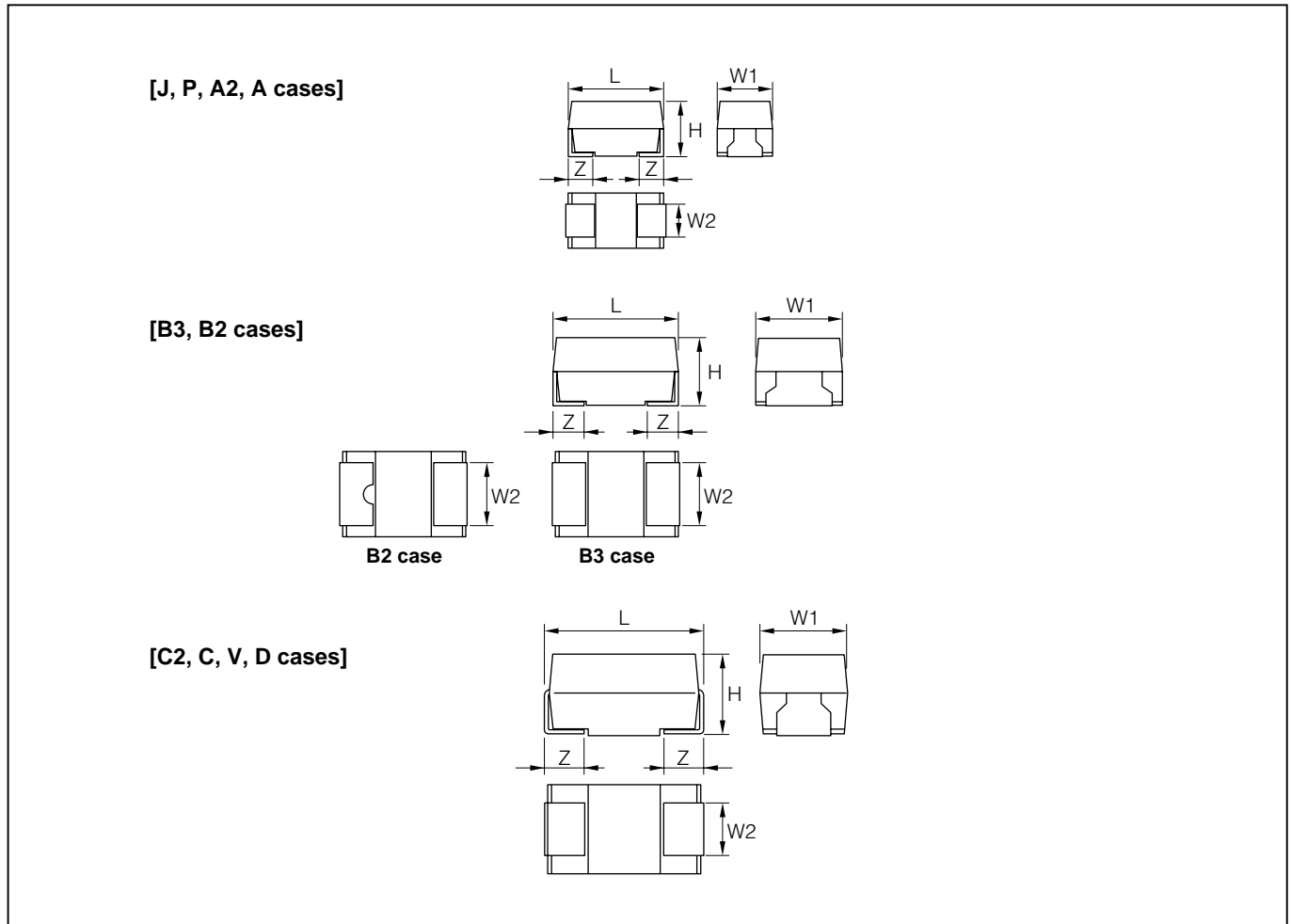

(Unit: mm)

Case Code	EIA code	L	W ₁	W ₂	H	Z
J	—	1.6 ± 0.1	0.8 ± 0.1	0.6 ± 0.1	0.8 ± 0.1	0.3 ± 0.15
P	2012	2.0 ± 0.2	1.25 ± 0.2	0.9 ± 0.1	1.1 ± 0.1	0.5 ± 0.1
A2 (U)	3216L	3.2 ± 0.2	1.6 ± 0.2	1.2 ± 0.1	1.1 ± 0.1	0.8 ± 0.2
A	3216	3.2 ± 0.2	1.6 ± 0.2	1.2 ± 0.1	1.6 ± 0.2	0.8 ± 0.2
B3 (W)	3528L	3.5 ± 0.2	2.8 ± 0.2	2.2 ± 0.1	1.1 ± 0.1	0.8 ± 0.2
B2 (S)	3528	3.5 ± 0.2	2.8 ± 0.2	2.2 ± 0.1	1.9 ± 0.2	0.8 ± 0.2
C2	—	6.0 ± 0.2	3.2 ± 0.2	2.2 ± 0.1	1.4 ± 0.1	1.3 ± 0.2
C	6032	6.0 ± 0.2	3.2 ± 0.2	2.2 ± 0.1	2.5 ± 0.2	1.3 ± 0.2
V	—	7.3 ± 0.2	4.3 ± 0.2	2.4 ± 0.1	1.9 ± 0.1	1.3 ± 0.2
D	7343	7.3 ± 0.2	4.3 ± 0.2	2.4 ± 0.1	2.8 ± 0.2	1.3 ± 0.2

■ STANDARD C-V VALUE REFERENCE BY CASE CODE

μF	U_R	2.5V	4V	6.3V	10V	16V	20V	25V	35V
		0E	0G	0J	1A	1C	1D	1E	1V
0.47	474					P	A2	A	A
0.68	684					P	A2	A	A
1.0	105				P	J, P	A2	P, A2, A	A2, A
1.5	155			P	J, P	A	A2		A
2.2	225			J	J, P	P, A2, A, [J]	P, A2, A	A, [P]	A, B2
3.3	335		P	J	P, A2	A2, A	A, B3	A	B2, [B3]
4.7	475			J, P, A	J, P, A2, A	A2, A	A2, A, B3, B2	B3, B2, [A2]	C
6.8	685		J	J, P, A2	A2, A	A, B3	B2		C
10	106	J	J, P	J, P, A2, A	P, A2, A, B2	A, B3, B2	B2	C, [B2]	C, D
15	156		P	P, A2, A	B3, [P]	B2, [A]	C	C	D
22	226	P, A2	P, A2, A	P, A2, A, B3, B2	A, B3, B2, [A2]	B3, B2, C	C2, C, D	D	
33	336	P, A2	P, A2, A	A, B3, [A2]	B3, B2, [A]	C2, C, [B2]	D	D	
47	476	P, A2, A	P, A2, A, B3	A, B3, B2, C	B2, C2, C, [B3]	C, D	D	[D]	
68	686	A	A, B3	B2, C2	B2, C2, C	C, D			
100	107	B3, B2	A, B3, B2, C2	B2, C2, C, [B3]	C, V, D, [C2]	D			
150	157	A, B3, C2	B2, C2	C	V, D				
220	227	B2, C2	B2, C	C, V, D	D				
330	337	B2, C	C, V	D					
470	477	C, D	D	D					
680	687		D						

[] : Under development

■ PART NUMBER SYSTEM

[Bulk]

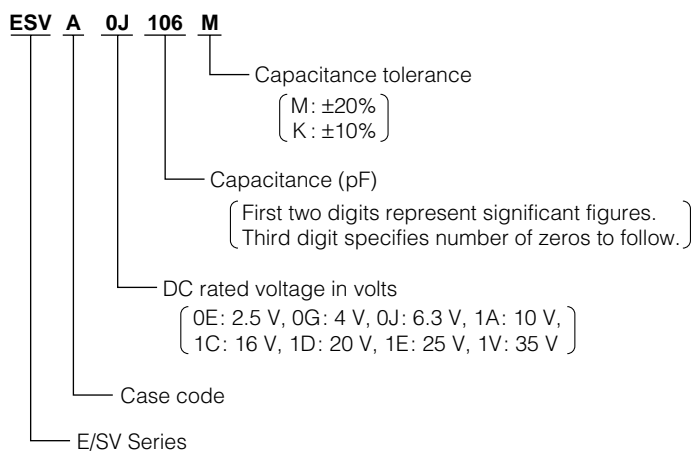

[Tape and Reel]

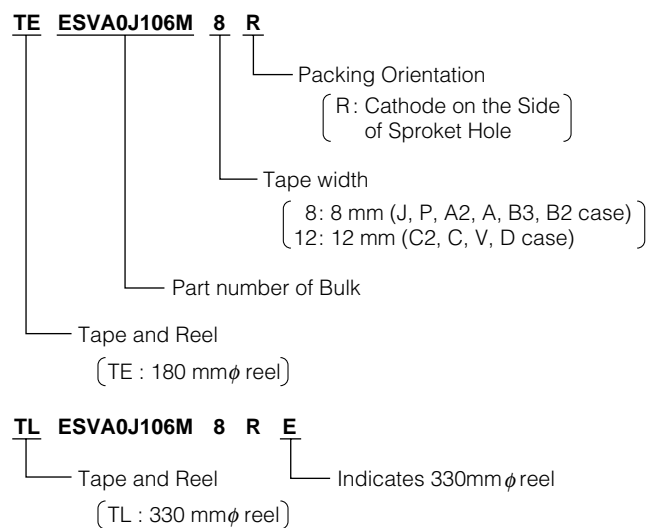

■ MARKINGS

The standard marking shows capacitance, DC rated voltage, and polarity.

[J case] (ex. 4.7 μ F / 6.3 V)

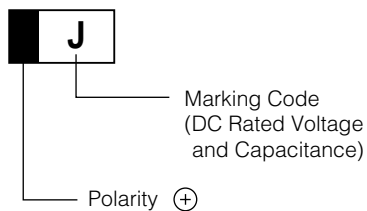

[J case Marking Code]

μ F \ U _R	2.5 V	4 V	6.3 V	10 V	16 V
1.0					⊖
1.5				∇	
2.2			∩	Λ	
3.3			∩		
4.7			J	∇	
6.8		G	∩		
10	e	⊖	∩		

[P case] (ex. 1 μ F / 10 V)

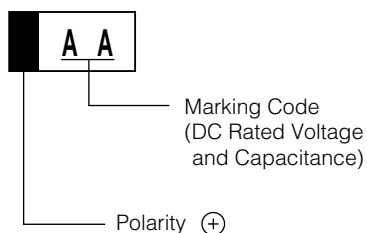

[P case Marking Code]

μ F \ U _R	2.5 V	4 V	6.3 V	10 V	16 V	20 V	25 V
0.47					CS		
0.68					CW		
1				AA	CA		EA
1.5			JE	AE			
2.2				AJ	CJ	DJ	
3.3		GN		AN			
4.7			JS	AS			
6.8			JW				
10		GĀ	JĀ	AĀ			
15		GĒ	JĒ				
22	eJ	GJ	JJ				
33	eN	GN					
47	eS	GS					

[A2, A cases] (ex. 10 μ F / 6.3 V)

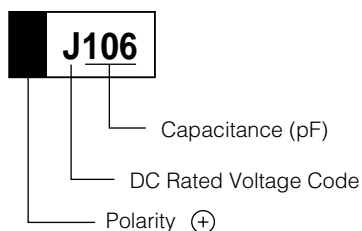

[P, A2, A, cases DC Rated Voltage code]

Code	e	G	J	A	C	D	E	V
Rated Voltage	2.5 V	4 V	6.3 V	10 V	16 V	20 V	25 V	35 V

[B3, B2 cases] (ex. 47 μ F / 6.3 V)

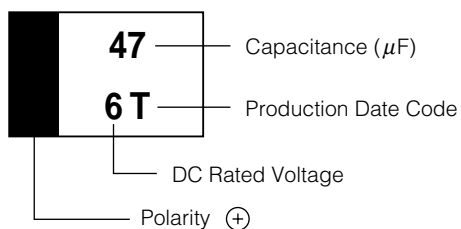

[B3, B2, C2, C, V, D cases Production date code]

Y \ M	Jan.	Feb.	Mar.	Apr.	May	Jun.	Jul.	Aug.	Sep.	Oct.	Nov.	Dec.
2003	a	b	c	d	e	f	g	h	j	k	l	m
2004	n	p	q	r	s	t	u	v	w	x	y	z
2005	A	B	C	D	E	F	G	H	J	K	L	M
2006	N	P	Q	R	S	T	U	V	W	X	Y	Z

Note: Production date code will repeat beginning in 2007.

[C2, C, V, D cases] (ex. 220 μ F / 6.3 V)

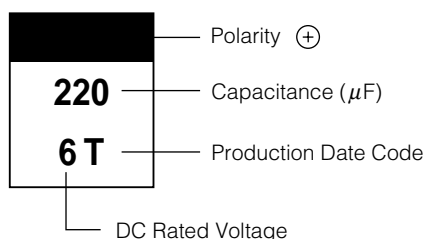

■ PERFORMANCE CHARACTERISTICS

Test Conditions : Conform to IEC 60384-1

ITEM		PERFORMANCE							TEST CONDITION	
Operating temperature		-55°C to +125°C							Derate voltage at 85°C at more	
Rated voltage (V.dc)		2.5V	4V	6.3V	10V	16V	20V	25V	35V	at 85°C
Derated voltage (V.dc)		1.6V	2.5V	4V	6.3V	10V	13V	16V	22V	at 125°C
Surge voltage (V.dc)		3.3V	5.2V	8V	13V	20V	26V	33V	46V	at 85°C
Capacitance		0.47 μF to 680 μF							at 120 Hz	
Capacitance tolerance		±20% or ±10% (P,J case: ±20%)								
DC Leakage Current (L.C)		0.01C • V(μA) or 0.5 μA , whichever is greater							Voltage: Rated voltage for 5min.	
Dissipation Factor		Refer to Standard Ratings							at 120 Hz	
Equivalent Series Resistance		Refer to Standard Ratings							at 100 kHz	
		Capacitance change	DF(%)			L.C				
Surge voltage test		Refer to Standard Ratings	Lower than initial specification			Lower than initial specification			Temperature : 85±2°C Applied voltage : Surge voltage Series resistance : 33 ohm Duration of surge : 30±5 sec Time between surge : 5.5min. Number of cycle : 1000	
Characteristic at high and low temperature	-55°C	Not to exceed -20% (P, J case) or -12%	Refer to Standard Ratings			—————			Step 1: 25±2°C Step 2: -55.0°C Step 3: 25±2°C Step 4: 125.0°C	
	+85°C	Not to exceed +20% (P, J case) or +12%	Lower than initial specification			0.1C•V(μA) or 5μA, which ever is greater				
	+125°C	Not to exceed +20% (P, J case) or +15%	Refer to Standard Ratings			0.125C•V(μA) or 6.25μA, which ever is greater				
Rapid change of temperature		Refer to Standard Ratings	Lower than initial specification			Lower than initial specification			Parts shall be temperature cycled over a temperature range of -55 to +125°C, five times continuously as follow. Step 1: -55.0°C, 30±3min. Step 2: room temp. , 10 to 15min. Step 3: 125.0°C, 30±3min. Step 4: room temp, 10 to 15min.	
Resistance to Soldering heat		Refer to Standard Ratings	Lower than initial specification			Lower than initial specification			solder dip : 260°C, 5sec solder reflow : 260°C,10sec	
Damp heat		Refer to Standard Ratings	Lower than 1.5 times initial specification			Lower than initial specification			at 40°C at 90 to 95% RH 500 hour	
Endurance		Refer to Standard Ratings	Lower than initial specification			Lower than 2 times initial specification (P, J case) or 1.25 times initial specification			at 85°C: Rated voltage at 125°C: Derated voltage 2000 hour	
Failure Rate		λ ₀ =1% / 1000 hour							at 85°C: Rated voltage at 125°C: Derated voltage 2000 hour	
Terminal Strength		Visual: There shall be no evidence of mechanical damage							Strength : 4.9N Time : 10±0.5sec. (two directions)	

Reference : Derated voltage (85 to 125°C)

$$[U_T] = [U_R] - \frac{[U_R] - [U_C]}{40} (T-85)$$

[U_T] : Derated voltage at operating temperature

[U_R] : Rated voltage

[U_C] : Derated voltage at 125°C

T : Ambient temperature

■ STANDARD RATINGS

Rated Voltage (V)	Capacitance (μF)	Case Code	Part Number (Bulk)	Leakage Current (μA)	DF (%)	ESR (Ω)	DF (%)		Capacitance	
							-55°C	+125°C	Change 1	Change 2
2.5	10	J	ESVJ0E106M	0.5	20	6.5	30	30	±20%	±20%
	22	P	ESVP0E226M	0.5	20	4	30	30	±20%	±20%
	22	A2	ESVA20E226M	0.5	12	3	20	14	±12%	±12%
	33	A2	ESVA20E336M	0.8	12	4	22	14	±12%	±12%
	33	P	ESVP0E336M	0.8	20	4	30	30	±20%	±20%
	47	P	ESVP0E476M	1.1	30	6	60	40	±20%	±20%
	47	A2	ESVA20E476M	1.1	12	4.5	22	14	±12%	±12%
	47	A	ESVA0E476M	1.2	12	4.5	22	16	±12%	±12%
	68	A	ESVA0E686M	1.7	18	4.5	34	20	±12%	±12%
	100	B3	ESVB30E107M	2.5	18	1.3	34	20	±15%	±15%
	100	B2	ESVB20E107M	2.5	8	1	14	10	±12%	±12%
	150	A	ESVA0E157M	3.7	30	2	60	40	±20%	±20%
	150	B3	ESVB30E157M	3.7	20	1	40	30	±15%	±15%
	150	C2	ESVC20E157M	3.7	12	0.8	26	18	±12%	±12%
	220	B2	ESVB20E227M	5.5	18	0.6	34	20	±12%	±12%
	220	C2	ESVC20E227M	5.5	12	0.8	26	18	±12%	±12%
	330	B2	ESVB20E337M	8.2	25	0.6	50	30	±12%	±20%
330	C	ESVC0E337M	8.2	16	0.3	34	18	±12%	±12%	
470	C	ESVC0E477M	11.7	18	1.5	34	20	±12%	±12%	
470	D	ESVD0E477M	11.7	14	0.5	18	16	±12%	±12%	
4	3.3	P	ESVP0G335M	0.5	20	20	30	30	±20%	±20%
	6.8	J	ESVJ0G685M	0.5	20	7.5	30	30	±20%	±20%
	10	J	ESVJ0G106M	0.5	20	6.5	30	30	±20%	±20%
	10	P	ESVP0G106M	0.5	20	6	30	30	±20%	±20%
	15	P	ESVP0G156M	0.6	20	5	30	30	±20%	±20%
	22	P	ESVP0G226M	0.8	20	4	30	30	±20%	±20%
	22	A2	ESVA20G226M	0.8	12	2.8	22	16	±12%	±12%
	22	A	ESVA0G226M	0.8	8	2.5	12	10	±12%	±12%
	33	P	ESVP0G336M	1.3	20	4	30	30	±20%	±20%
	33	A2	ESVA20G336M	1.3	8	4.5	14	10	±12%	±12%
	33	A	ESVA0G336M	1.3	10	3	14	12	±12%	±12%
	47	P	ESVP0G476M	1.8	30	3	60	40	±20%	±20%
	47	A2	ESVA20G476M	1.8	15	4.5	30	20	±12%	±12%
	47	A	ESVA0G476M	1.8	12	2.5	22	14	±12%	±12%
	47	B3	ESVB30G476M	1.8	12	1.7	18	15	±15%	±15%
	68	A	ESVA0G686M	2.7	12	2.5	22	14	±12%	±12%
	68	B3	ESVB30G686M	2.7	15	1.5	28	17	±15%	±15%
	100	A	ESVA0G107M	4	30	2	60	40	±20%	±20%
	100	B3	ESVB30G107M	4	20	1.3	38	22	±15%	±15%
	100	B2	ESVB20G107M	4	12	0.8	22	14	±12%	±12%
	100	C2	ESVC20G107M	4	10	0.8	18	12	±12%	±12%
	150	B2	ESVB20G157M	6	18	0.7	34	20	±12%	±12%
	150	C2	ESVC20G157M	6	10	0.8	18	12	±12%	±12%
	220	B2	ESVB20G227M	8.8	18	0.5	34	20	±12%	±12%
220	C	ESVC0G227M	8.8	12	0.6	22	14	±12%	±12%	
330	C	ESVC0G337M	13.2	14	0.2	26	16	±12%	±12%	
330	V	ESVV0G337M	13.2	12	0.5	18	14	±12%	±12%	
470	D	ESVD0G477M	18.8	16	0.3	30	18	±12%	±12%	
680	D	ESVD0G687M	27.2	24	0.3	46	26	±12%	±12%	
6.3	1.5	P	ESVP0J155M	0.5	10	25	15	15	±20%	±20%
	2.2	J	ESVJ0J225M	0.5	20	17.5	30	30	±20%	±20%
	3.3	J	ESVJ0J335M	0.5	20	13.5	30	30	±20%	±20%
	4.7	J	ESVJ0J475M	0.5	20	8.5	30	30	±20%	±20%
	4.7	P	ESVP0J475M	0.5	20	10	30	30	±20%	±20%
	4.7	A	ESVA0J475M	0.5	8	5.5	12	10	±5%	±10%
	6.8	J	ESVJ0J685M	0.5	20	7	30	30	±20%	±20%
	6.8	P	ESVP0J685M	0.5	20	7	30	30	±20%	±20%
	6.8	A2	ESVA20J685M	0.5	8	6.5	12	10	±12%	±12%
	10	J	ESVJ0J106M	0.6	20	8	38	22	±20%	±20%
	10	P	ESVP0J106M	0.6	20	6	30	30	±20%	±20%
	10	A2	ESVA20J106M	0.6	8	4.5	12	10	±12%	±12%
	10	A	ESVA0J106M	0.6	8	3.2	12	10	±12%	±12%
	15	P	ESVP0J156M	0.9	20	5	30	30	±20%	±20%
	15	A2	ESVA20J156M	0.9	12	4	22	14	±12%	±12%
	15	A	ESVA0J156M	0.9	8	3	12	10	±12%	±12%

Rated Voltage (V)	Capacitance (μF)	Case Code	Part Number (Bulk)	Leakage Current (μA)	DF (%)	ESR (Ω)	DF (%)		Capacitance	
							-55°C	+125°C	Change 1	Change 2
6.3	22	P	ESVP0J226M	1.3	20	4	38	22	±20%	±20%
	22	A2	ESVA20J226M	1.3	12	2.8	22	14	±12%	±12%
	22	A	ESVA0J226M	1.3	10	3	14	12	±12%	±12%
	22	B3	ESVB30J226M	1.3	8	2	12	10	±15%	±15%
	22	B2	ESVB20J226M	1.3	8	1.6	12	10	±5%	±10%
	33	A	ESVA0J336M	2	12	2.5	22	14	±12%	±12%
	33	B3	ESVB30J336M	2	12	1.7	18	15	±15%	±15%
	47	A	ESVA0J476M	2.9	12	2	22	14	±12%	±12%
	47	B3	ESVB30J476M	2.9	12	1.7	18	15	±15%	±15%
	47	B2	ESVB20J476M	2.9	8	1.3	12	10	±5%	±10%
	47	C	ESVC0J476M	2.9	8	0.9	12	10	±5%	±10%
	68	B2	ESVB20J686M	4.2	10	1	18	12	±12%	±12%
	68	C2	ESVC20J686M	4.2	10	0.8	14	12	±12%	±12%
	100	B2	ESVB20J107M	6.3	12	0.9	22	14	±12%	±12%
	100	C2	ESVC20J107M	6.3	10	0.8	14	12	±12%	±12%
	100	C	ESVC0J107M	6.3	10	0.6	14	12	±12%	±12%
	150	C	ESVC0J157M	9.4	10	0.6	18	12	±12%	±12%
	220	C	ESVC0J227M	13.8	14	1.2	26	16	±12%	±12%
	220	V	ESVV0J227M	13.8	12	0.5	18	14	±12%	±12%
220	D	ESVD0J227M	13.8	12	0.5	18	14	±12%	±12%	
330	D	ESVD0J337M	20.7	14	0.5	26	16	±12%	±12%	
470	D	ESVD0J477M	29.6	20	0.3	38	22	±20%	±20%	
10	1	P	ESVP1A105M	0.5	10	25	15	15	±20%	±20%
	1.5	J	ESVJ1A155M	0.5	20	25.5	30	30	±20%	±20%
	1.5	P	ESVP1A155M	0.5	20	25	30	30	±20%	±20%
	2.2	J	ESVJ1A225M	0.5	20	17.5	30	30	±20%	±20%
	2.2	P	ESVP1A225M	0.5	20	19	30	30	±20%	±20%
	3.3	P	ESVP1A335M	0.5	20	13	30	30	±20%	±20%
	3.3	A2	ESVA21A335M	0.5	8	8	12	10	±12%	±12%
	4.7	J	ESVJ1A475M	0.5	20	10	30	30	±20%	±20%
	4.7	P	ESVP1A475M	0.5	20	6	30	30	±20%	±20%
	4.7	A2	ESVA21A475M	0.5	8	8	12	10	±12%	±12%
	4.7	A	ESVA1A475M	0.5	8	4.5	12	10	±12%	±12%
	6.8	A2	ESVA21A685M	0.6	8	8	12	10	±12%	±12%
	6.8	A	ESVA1A685M	0.6	8	4.5	12	10	±12%	±12%
	10	P	ESVP1A106M	1	20	6	30	30	±20%	±20%
	10	A2	ESVA21A106M	1	8	8	12	10	±12%	±12%
	10	A	ESVA1A106M	1	8	3.2	12	10	±12%	±12%
	10	B2	ESVB21A106M	1	8	2.4	12	10	±5%	±10%
	15	B3	ESVB31A156M	1.5	8	2.7	12	10	±15%	±15%
	22	A	ESVA1A226M	2.2	12	2.5	22	14	±12%	±12%
	22	B3	ESVB31A226M	2.2	8	1.9	12	10	±15%	±15%
	22	B2	ESVB21A226M	2.2	8	1.4	12	10	±5%	±10%
	33	B3	ESVB31A336M	1.7	12	1.7	18	15	±15%	±15%
	33	B2	ESVB21A336M	3.3	8	1.4	12	10	±5%	±10%
	47	B2	ESVB21A476M	4.7	8	1	12	10	±12%	±12%
	47	C2	ESVC21A476M	4.7	8	1	12	10	±12%	±12%
	47	C	ESVC1A476M	4.7	8	0.9	12	10	±5%	±10%
	68	C2	ESVC21A686M	6.8	10	1	18	14	±12%	±12%
	68	B2	ESVB21A686M	6.8	12	0.9	14	14	±12%	±12%
68	C	ESVC1A686M	6.8	8	0.7	12	10	±12%	±12%	
100	C	ESVC1A107M	10	10	0.5	18	12	±12%	±12%	
100	V	ESVV1A107M	10	8	0.5	18	10	±12%	±12%	
100	D	ESVD1A107M	10	8	0.6	18	10	±5%	±10%	
150	V	ESVV1A157M	15	8	0.5	18	10	±12%	±12%	
150	D	ESVD1A157M	15	10	0.6	18	12	±12%	±12%	
220	D	ESVD1A227M	22	12	0.6	22	14	±12%	±12%	
16	0.47	P	ESVP1C474M	0.5	10	35	15	15	±20%	±20%
	0.68	P	ESVP1C684M	0.5	10	25	15	15	±20%	±20%
	1	J	ESVJ1C105M	0.5	10	25.5	30	15	±20%	±20%
	1	P	ESVP1C105M	0.5	10	20	15	15	±20%	±20%
	1.5	A	ESVA1C155M	0.5	4	6	8	6	±5%	±10%
	2.2	P	ESVP1C225M	0.5	10	19	15	15	±20%	±20%
	2.2	A2	ESVA21C225M	0.5	6	10	10	8	±12%	±12%
	2.2	A	ESVA1C225M	0.5	6	6	10	8	±5%	±10%
3.3	A2	ESVA21C335M	0.5	8	7	14	10	±12%	±12%	

Rated Voltage (V)	Capacitance (μF)	Case Code	Part Number (Bulk)	Leakage Current (μA)	DF (%)	ESR (Ω)	DF (%)		Capacitance	
							-55°C	+125°C	Change 1	Change 2
16	3.3	A	ESVA1C335M	0.5	6	4.5	10	8	±12%	±12%
	4.7	A2	ESVA21C475M	0.7	8	4.5	14	10	±12%	±12%
	4.7	A	ESVA1C475M	0.7	6	4	10	8	±12%	±12%
	6.8	A	ESVA1C685M	1	6	4	10	8	±12%	±12%
	6.8	B3	ESVB31C685M	1	6	4.1	10	8	±15%	±15%
	10	A	ESVA1C106M	1.6	8	3.2	12	10	±12%	±12%
	10	B3	ESVB31C106M	1.6	8	3.5	14	10	±15%	±15%
	10	B2	ESVB21C106M	1.6	6	2	10	8	±5%	±10%
	15	B2	ESVB21C156M	2.4	6	2	10	8	±5%	±10%
	22	B3	ESVB31C226M	3.5	10	2.2	18	12	±15%	±15%
	22	B2	ESVB21C226M	3.5	6	2.2	10	8	±5%	±10%
	22	C	ESVC1C226M	3.5	6	1.5	10	8	±5%	±10%
	33	C2	ESVC21C336M	5.2	6	1.4	10	8	±12%	±12%
	33	C	ESVC1C336M	5.2	6	0.9	10	8	±5%	±10%
	47	C	ESVC1C476M	7.5	6	0.8	10	8	±12%	±12%
47	D	ESVD1C476M	7.5	6	0.7	10	8	±5%	±10%	
68	C	ESVC1C686M	10.8	6	0.7	16	10	±12%	±12%	
68	D	ESVD1C686M	10.8	6	0.7	10	8	±5%	±10%	
100	D	ESVD1C107M	16	8	0.5	18	10	±12%	±12%	
20	0.47	A2	ESVA21D474M	0.5	6	25	10	8	±5%	±10%
	0.68	A2	ESVA21D684M	0.5	6	15	10	8	±5%	±10%
	1	A2	ESVA21D105M	0.5	6	12	10	8	±12%	±12%
	1.5	A2	ESVA21D155M	0.5	6	7.4	10	8	±12%	±12%
	2.2	P	ESVP1D225M	0.5	10	8	15	15	±20%	±20%
	2.2	A2	ESVA21D225M	0.5	6	7	10	8	±12%	±12%
	2.2	A	ESVA1D225M	0.5	6	6	10	8	±12%	±12%
	3.3	A	ESVA1D335M	0.6	6	5	10	8	±12%	±12%
	3.3	B3	ESVB31D335M	0.6	6	3.9	10	8	±15%	±15%
	4.7	A2	ESVA21D475M	0.9	15	5	30	20	±15%	±15%
	4.7	A	ESVA1D475M	0.9	6	5	10	8	±12%	±12%
	4.7	B3	ESVB31D475M	0.9	6	3	10	8	±15%	±15%
	4.7	B2	ESVB21D475M	0.9	6	3	10	8	±5%	±10%
	6.8	B2	ESVB21D685M	1.3	6	2.8	10	8	±5%	±10%
	10	B2	ESVB21D106M	2	6	2.5	10	8	±5%	±10%
	15	C	ESVC1D156M	3	6	1.7	10	8	±5%	±10%
	22	C2	ESVC21D226M	4.4	6	1.4	10	8	±12%	±12%
22	C	ESVC1D226M	4.4	6	1.4	10	8	±5%	±10%	
22	D	ESVD1D226M	4.4	6	0.8	10	8	±5%	±10%	
33	D	ESVD1D336M	6.6	6	0.8	10	8	±5%	±10%	
47	D	ESVD1D476M	9.4	6	0.7	10	8	±5%	±10%	
25	0.47	A	ESVA1E474M	0.5	4	13	8	6	±5%	±10%
	0.68	A	ESVA1E684M	0.5	6	9	10	8	±5%	±10%
	1	P	ESVP1E105M	0.5	6	8	10	8	±20%	±20%
	1	A2	ESVA21E105M	0.5	6	13	10	8	±12%	±12%
	1	A	ESVA1E105M	0.5	6	8	10	8	±5%	±10%
	2.2	A	ESVA1E225M	0.5	6	7	10	8	±12%	±12%
	3.3	A	ESVA1E335M	0.8	6	7	10	8	±12%	±12%
	4.7	B3	ESVB31E475M	1.1	6	3	10	8	±15%	±15%
	4.7	B2	ESVB21E475M	1.1	6	3	10	8	±5%	±10%
	10	C	ESVC1E106M	2.5	6	1.2	10	8	±5%	±10%
	15	C	ESVC1E156M	3.7	6	1.5	10	8	±12%	±12%
	22	D	ESVD1E226M	5.5	6	0.8	10	8	±5%	±10%
33	D	ESVD1E336M	8.2	6	0.7	10	8	±5%	±10%	
35	0.47	A	ESVA1V474M	0.5	6	12	10	8	±5%	±10%
	0.68	A	ESVA1V684M	0.5	6	8	10	8	±5%	±10%
	1	A2	ESVA21V105M	0.5	6	13	10	8	±12%	±12%
	1	A	ESVA1V105M	0.5	6	7	10	8	±12%	±12%
	1.5	A	ESVA1V155M	0.5	6	7	10	8	±12%	±12%
	2.2	A	ESVA1V225M	0.7	6	7	10	8	±12%	±12%
	2.2	B2	ESVB21V225M	0.7	6	4	10	8	±5%	±10%
	3.3	B2	ESVB21V335M	1.1	6	3.5	10	8	±5%	±10%
	4.7	C	ESVC1V475M	1.6	6	2.2	10	8	±5%	±10%
	6.8	C	ESVC1V685M	2.3	6	1.3	10	8	±5%	±10%
	10	C	ESVC1V106M	3.5	6	1.5	10	8	±5%	±10%
	10	D	ESVD1V106M	3.5	6	1	10	8	±5%	±10%
	15	D	ESVD1V156M	5.2	6	0.9	10	8	±5%	±10%