

## F/SV Series Tantalum Chip Capacitors

### New Product

#### FEATURE

- Lead-free type. In conformity to RoHS.
- Face down terminal
- The low-profile of height 0.9mm Max and large capacitance of 47 $\mu$ F available in 1608 size.
- Enable fillet bonding

#### DIMENSIONS

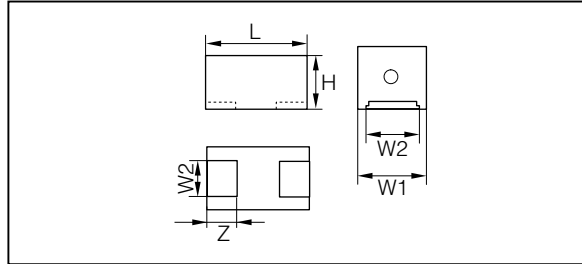

(Unit: mm)

Case Code	L	W <sub>1</sub>	W <sub>2</sub>	H	Z
J	1.6±0.1	0.85±0.1	0.65±0.1	0.8±0.1	0.5±0.05
P2 *	2.0±0.1	1.25±0.1	0.9±0.1	0.9±0.1	0.5±0.1
A3 *	3.2±0.2	1.6±0.2	1.2±0.1	0.9±0.1	0.8±0.2

\* Under development

#### STANDARD C-V VALUE REFERENCE BY CASE CODE

UR :Rated Voltage

$\mu$ F	UR	2.5	4	6.3	10	16	20	25
		0E	0G	0J	1A	1C	1D	1E
1							[J]	
1.5								
2.2								[P2]
3.3								
4.7	475					[J]	[P2]	[A3]
6.8	685							
10	106				[J]	[P2]	[A3]	
15	156							
22	226			[J]	[P2]	[A3]		
33	336		J	[P2]				
47	476	J		[P2]	[A3]			
68	686		[P2]					
100	107	[P2]	[P2]	[A3]				
220	227	[A3]	[A3]					

[ ] :Under development

■ PART NUMBER SYSTEM

[Bulk]

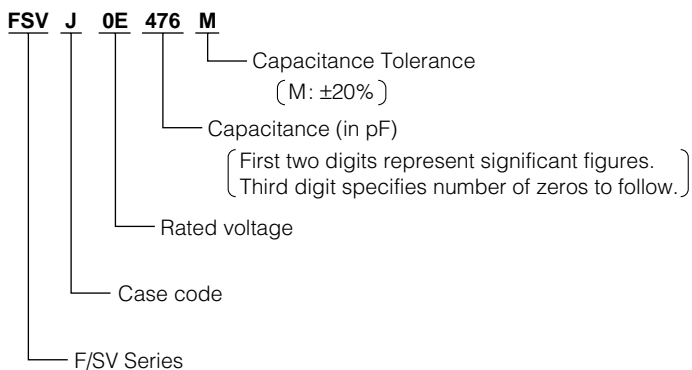

[Tape and Reel]

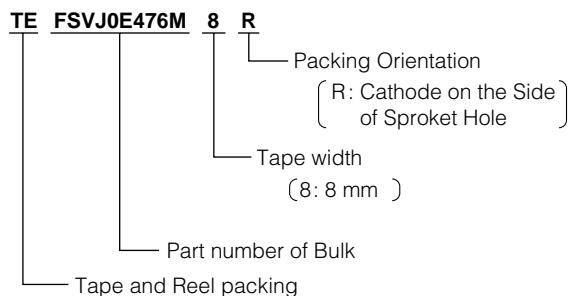

■ MARKINGS

[J case]

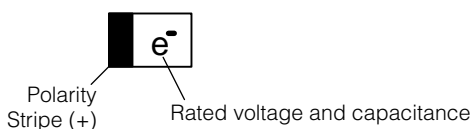

[P2 case] Under development

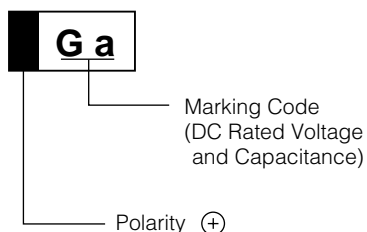

[A3 case] Under development

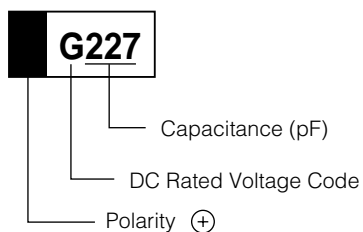

[Rated voltage and capacitance]

[J case Marking code]

UR :Rated Voltage

μF \ UR	UR					
	2.5	4	6.3	10	16	20
	0E	0G	0J	1A	1C	1D
1.0	105					[D <sup>-</sup> ]
1.5	155					
2.2	225					
3.3	335					
4.7	475				[O <sup>-</sup> ]	
6.8	685					
10	106			[< <sup>-</sup> ]		
15	156					
22	226		[J <sup>-</sup> ]			
33	336		G <sup>-</sup>			
47	476	e <sup>-</sup>				

[ ] : Under development

[P2 case Marking code]

UR :Rated Voltage

μF \ UR	UR						
	2.5	4	6.3	10	16	20	25
	0E	0G	0J	1A	1C	1D	1E
2.2	225						EJ
3.3	335						
4.7	475					DS	
6.8	685						
10	106				C <sup>-</sup> A		
15	156						
22	226			A <sup>-</sup> J			
33	336		J <sup>-</sup> N				
47	476		J <sup>-</sup> S				
68	686		G <sup>-</sup> W				
100	107	ea	Ga				

[A3 case DC Rated Voltage code]

Code	e	G	J	A	C	D	E
Rated Voltage	2.5 V	4 V	6.3 V	10 V	16 V	20 V	25 V

■ PERFORMANCE CHARACTERISTICS

Test Conditions : Conform to IEC 60384-1

ITEM		PERFORMANCE						TEST CONDITION	
Operating temperature		-55°C to +125°C						Derate voltage at 85°C at more	
Rated voltage (V.dc)		2.5V	4V	[6.3V]	[10V]	[16V]	[20V]	[25V]	at 85°C
Derated voltage (V.dc)		1.6V	2.5V	[4V]	[6.3V]	[10V]	[13V]	[16V]	at 125°C
Surge voltage (V.dc)		3.3V	5.2V	[8V]	[13V]	[20V]	[26V]	[33V]	at 85°C
Capacitance		33 μF to 47 μF						at 120 Hz	
Capacitance tolerance		±20%							
DC Leakage Current (L.C)		0.01C • V(μA) or 0.5μA , whichever is greater						Voltage: Rated voltage for 5min.	
Dissipation Factor		Refer to Standard Ratings						at 120 Hz	
Equivalent Series Resistance		Refer to Standard Ratings						at 100 kHz	
		Capacitance change	DF(%)		L.C				
Surge voltage test		Refer to Standard Ratings	Lower than initial specification		Lower than initial specification			Temperature : 85±2°C Applied voltage : Surge voltage Series resistance : 33 ohm Duration of surge : 30±5 sec Time between surge : 5.5min. Number of cycle : 1000	
Characteristic at high and low temperature	-55°C	Not to exceed -20%	Refer to Standard Ratings		—			Step 1: 25±2°C Step 2: -55.0°C Step 3: 25±2°C Step 4: 125.0°C	
	+85°C	Not to exceed +20%	Lower than initial specification		0.1C•V(μA) or 5μA, which ever is greater				
	+125°C	Not to exceed +20%	Refer to Standard Ratings		0.125C•V(μA) or 6.25μA, which ever is greater				
Rapid change of temperature		Refer to Standard Ratings	Lower than initial specification		Lower than initial specification			Parts shall be temperature cycled over a temperature range of -55 to +125°C, five times continuously as follow. Step 1: -55.0°C, 30±3min. Step 2: room temp. , 10 to 15min. Step 3: 125.0°C, 30±3min. Step 4: room temp, 10 to 15min.	
Resistance to Soldering heat		Refer to Standard Ratings	Lower than initial specification		Lower than initial specification			solder dip : 260°C, 5sec solder reflow : 260°C, 10sec	
Damp heat		Refer to Standard Ratings	Lower than 1.5 times initial specification		Lower than initial specification			at 40°C at 90 to 95% RH 500 hour	
Endurance		Refer to Standard Ratings	Lower than initial specification		Lower than 2 times initial specification			at 85°C : Rated voltage at 125°C : Derated voltage 2000 hour	
Failure Rate		λ <sub>0</sub> =1% / 1000 hour						at 85°C: Rated voltage at 125°C: Derated voltage 2000 hour	
Terminal Strength		Visual: There shall be no evidence of mechanical damage						Strength : 4.9N Time : 10±0.5sec. (two directions)	

[ ] : Under development

Reference : Derated voltage (85 to 125°C)

$$[U_T] = [U_R] - \frac{[U_R] - [U_C]}{40} (T-85)$$

[U<sub>T</sub>] : Derated voltage at operating temperature

[U<sub>R</sub>] : Rated voltage

[U<sub>C</sub>] : Derated voltage at 125°C

T : Ambient temperature

■ RATINGS

Rated Voltage (V)	Capacitance (μF)	Case Code	Part Number (Bulk)	Leakage Current (μA)	DF (%)	ESR (Ω)	DF (%)		Capacitance	
							-55°C	+125°C	Change 1	Change 2
2.5	47	J	FSVJ0E476M	1.1	30	4	60	40	±20%	±20%
4	33	J	FSVJ0G336M	1.3	30	4	60	30	±20%	±20%

■ CHARACTERISTICS (reference)

Impedance-frequency characteristics

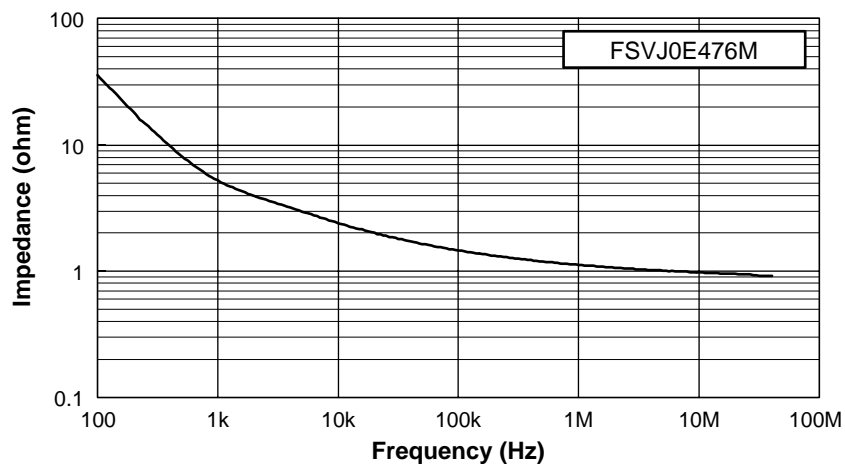

ESR-frequency characteristics

