

## SV/Z Series Tantalum Chip Capacitors (Low-ESR Type)

### ■ FEATURES

- Lead-free Type. In conformity to RoHS.
- Low-ESR Type.
- For decoupling with CPU, for absorbing the noise.
- Same Dimension as E/SV series.

### ■ DIMENSIONS [mm]

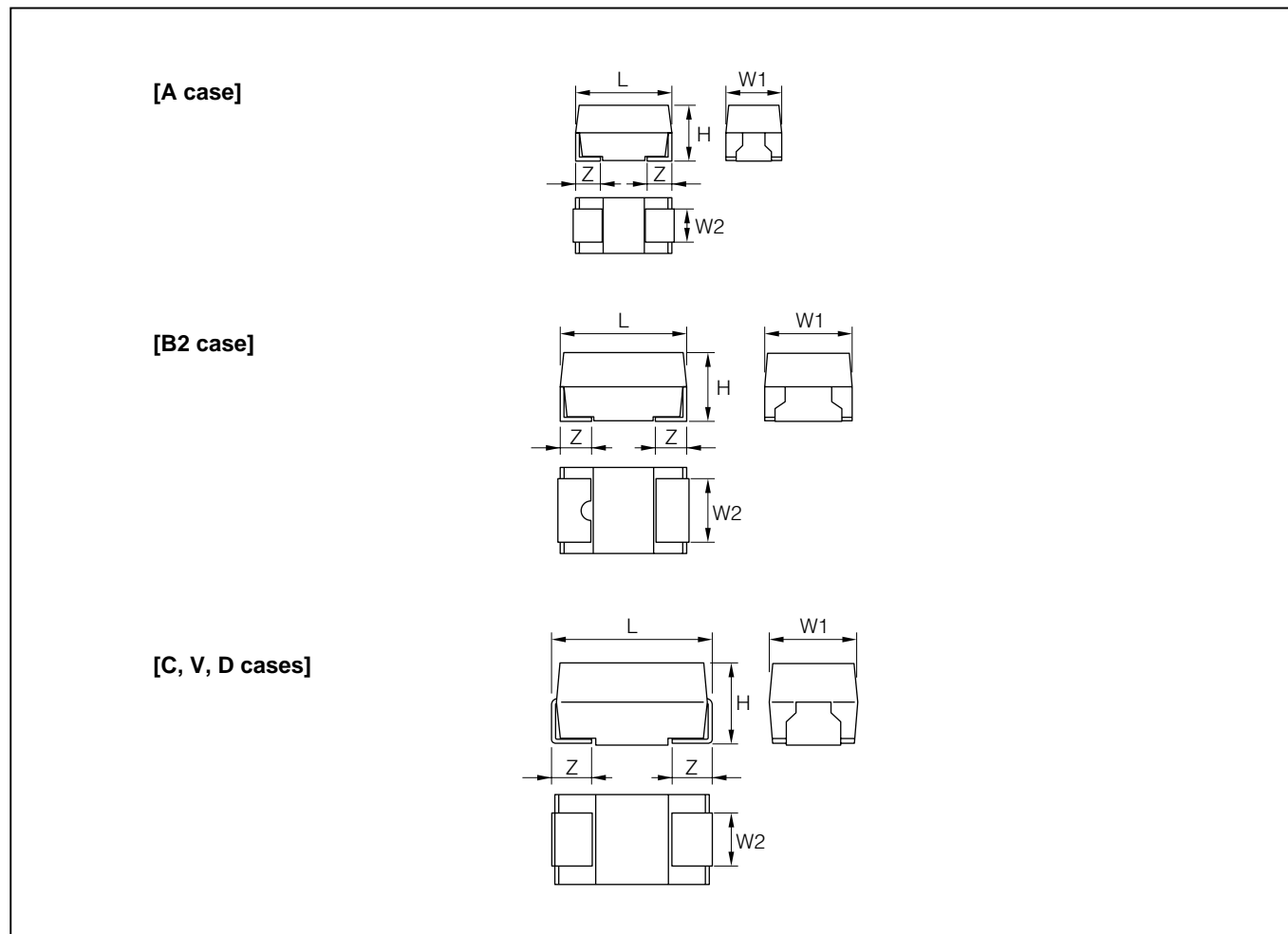

(Unit: mm)

Case Code	EIA code	L	W <sub>1</sub>	W <sub>2</sub>	H	Z
A	3216	3.2 ± 0.2	1.6 ± 0.2	1.2 ± 0.1	1.6 ± 0.2	0.8 ± 0.2
B2	3528	3.5 ± 0.2	2.8 ± 0.2	2.2 ± 0.1	1.9 ± 0.2	0.8 ± 0.2
C	6032	6.0 ± 0.2	3.2 ± 0.2	2.2 ± 0.1	2.5 ± 0.2	1.3 ± 0.2
V	7343L	7.3 ± 0.2	4.3 ± 0.2	2.4 ± 0.1	1.9 ± 0.1	1.3 ± 0.2
D	7343	7.3 ± 0.2	4.3 ± 0.2	2.4 ± 0.1	2.8 ± 0.2	1.3 ± 0.2

■ STANDARD C-V VALUE REFERENCE BY CASE CODE

$\mu\text{F}$ \ U <sub>R</sub>		4 V	6.3 V	10 V	16 V	20 V	25 V	35 V
		0G	0J	1A	1C	1D	1E	1V
6.8	685						C 600	C 600
10	106		A 800	B2 600				D 300
15	156						D 250	D 300
22	226		B2 800				D 200	
33	336					D 200		
47	476			C 300	D 150	D 150		
68	686			B2 250	C, D 200, 150			
100	107		C, D 150, 150	C, V, D 125, 150, 100	D 100			
150	157		C, D 125, 100	V, D 150, 100				
220	227	D 100	V, D 150, 100	D 100				
330	337	V, D 150, 100	D 100					

Number : ESR (mΩ)

■ PART NUMBER SYSTEM

[Bulk]

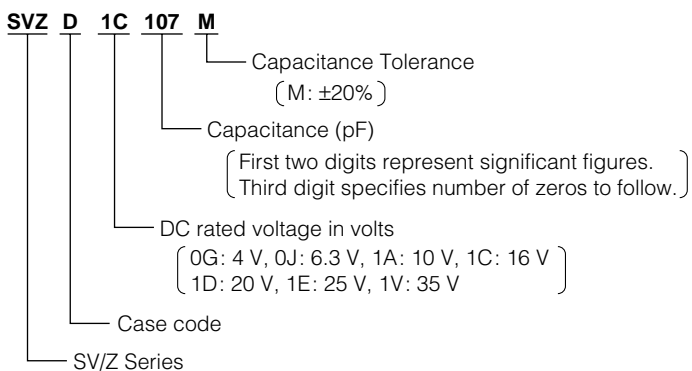

[Tape and Reel]

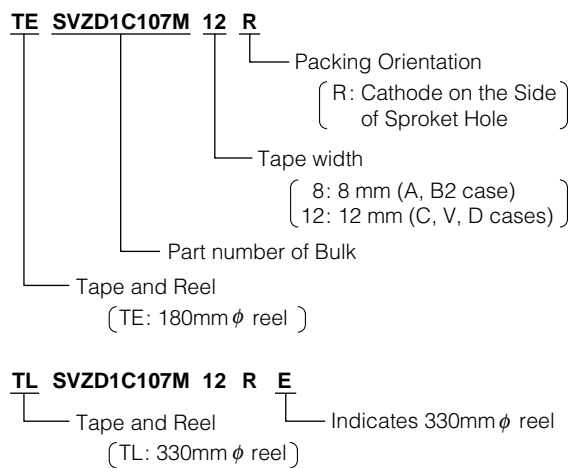

## MARKINGS

The standard marking shows capacitance, DC rated voltage, and polarity.

[A case] (ex. 10  $\mu$ F / 6.3 V)

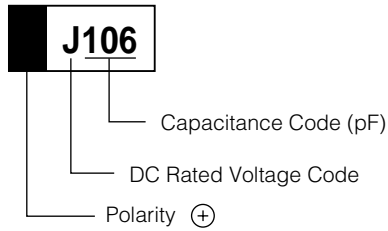

[B2 case] (ex. 22  $\mu$ F / 6.3 V)

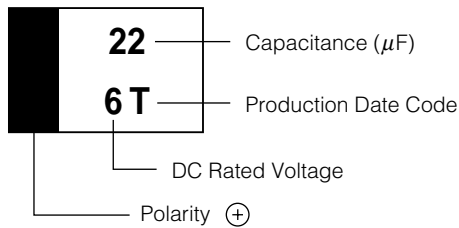

[C, V, D case] (ex. 220  $\mu$ F / 10 V)

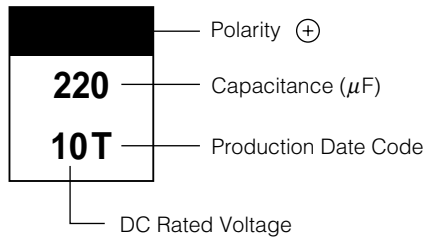

### [DC Rated Voltage code]

Code	G	J	A	C	D	E	V
Rated Voltage	4 V	6.3 V	10 V	16 V	20 V	25 V	35 V

### [B2, C, V, D cases production date code]

Y \ M	Jan.	Feb.	Mar.	Apr.	May	Jun.	Jul.	Aug.	Sep.	Oct.	Nov.	Dec.
2003	a	b	c	d	e	f	g	h	j	k	l	m
2004	n	p	q	r	s	t	u	v	w	x	y	z
2005	A	B	C	D	E	F	G	H	J	K	L	M
2006	N	P	Q	R	S	T	U	V	W	X	Y	Z

**Note:** Production date code will resume beginning in 2007.

## ■ PERFORMANCE CHARACTERISTICS

Test Conditions : Conform to IEC 60384-1

ITEM		PERFORMANCE						TEST CONDITION	
Operating temperature		-55°C to +125°C						Derate voltage at 85°C at more	
Rated voltage (V.dc)		4V	6.3V	10V	16V	20V	25V	35V	at 85°C
Derated voltage (V.dc)		2.5V	4V	6.3V	10V	13V	16V	22V	at 125°C
Surge voltage (V.dc)		5.2V	8V	13V	20V	26V	33V	46V	at 85°C
Capacitance		6.8 μF to 330 μF						at 120 Hz	
Capacitance tolerance		±20% or ±10%							
DC Leakage Current (L.C)		0.01C • V(μA) or 0.5μA , whichever is greater						Voltage: Rated voltage for 5min.	
Dissipation Factor		Refer to Standard Ratings						at 120 Hz	
Equivalent Series Resistance		Refer to Standard Ratings						at 100 kHz	
		Capacitance change	DF(%)		L.C				
Surge voltage test		Refer to Standard Ratings	Lower than initial specification		Lower than initial specification			Temperature : 85±2°C Applied voltage : Surge voltage Series resistance : 33 ohm Duration of surge : 30±5 sec Time between surge : 5.5min. Number of cycle : 1000	
Characteristic at high and low temperature	-55°C	Not to exceed -12%	Refer to Standard Ratings		—————			Step 1: 25±2°C Step 2: -55.0°C Step 3: 25±2°C Step 4: 125.0°C	
	+85°C	Not to exceed +12%	Lower than initial specification		0.1C • V(μA) or 5μA, which ever is greater				
	+125°C	Not to exceed +15%	Refer to Standard Ratings		0.125C • V(μA) or 6.25μA, which ever is greater				
Rapid change of temperature		Refer to Standard Ratings	Lower than initial specification		Lower than initial specification			Parts shall be temperature cycled over a temperature range of -55 to +125°C, five times continuously as follow. Step 1: -55.0°C, 30±3min. Step 2: room temp. , 10 to 15min. Step 3: 125.0°C, 30±3min. Step 4: room temp, 10 to 15min.	
Resistance to Soldering heat		Refer to Standard Ratings	Lower than initial specification		Lower than initial specification			solder dip : 260°C, 5sec solder reflow : 260°C, 10sec	
Damp heat		Refer to Standard Ratings	Lower than 1.25 times initial specification		Lower than initial specification			at 40°C at 90 to 95% RH 500 hour	
Endurance		Refer to Standard Ratings	Lower than initial specification		Lower than 1.25 times initial specification			at 85°C : Rated voltage at 125°C : Derated voltage 2000 hour	
Failure Rate		λ <sub>0</sub> = 1% / 1000 hour						at 85°C : Rated voltage at 125°C : Derated voltage 2000 hour	
Terminal Strength		Visual: There shall be no evidence of mechanical damage						Strength : 4.9N Time : 10±0.5sec. (two directions)	

Reference : Derated voltage (85 to 125°C)

$$[U_T] = [U_R] - \frac{[U_R] - [U_C]}{40} (T-85)$$

[U<sub>T</sub>] : Derated voltage at operating temperature[U<sub>R</sub>] : Rated voltage[U<sub>C</sub>] : Derated voltage at 125°C

T : Ambient temperature

■ STANDARD RATINGS

Rated Voltage (V)	Capacitance (μF)	Case Code	Part Number (Bulk)	Leakage Current (μA)	DF (%)	ESR (mΩ)	DF (%)		Capacitance	
							-55°C	+125°C	Change 1	Change 2
4	220	D	SVZD0G227M	8.8	8	100	18	10	± 5%	± 5%
	330	V	SVZV0G337M	13.2	12	150	18	14	±12%	±12%
	330	D	SVZD0G337M	13.2	14	100	18	16	±12%	±12%
6.3	10	A	SVZA0J106M	0.6	8	800	12	10	±12%	±12%
	22	B2	SVZB20J226M	1.3	8	800	12	10	± 5%	± 5%
	100	C	SVZC0J107M	6.3	10	150	14	12	±12%	±12%
	100	D	SVZD0J107M	6.3	8	150	12	10	± 5%	± 5%
	150	C	SVZC0J157M	9.4	10	125	18	12	±12%	±12%
	150	D	SVZD0J157M	9.4	8	100	18	10	± 5%	± 5%
	220	V	SVZV0J227M	13.8	12	150	18	14	±12%	±12%
	220	D	SVZD0J227M	13.8	12	100	18	14	±12%	±12%
	330	D	SVZD0J337M	20.7	14	100	26	16	±12%	±12%
10	10	B2	SVZB21A106M	1	8	600	12	10	± 5%	± 5%
	47	C	SVZC1A476M	4.7	8	300	12	10	± 5%	± 5%
	68	B2	SVZB21A686M	6.8	12	250	14	14	±12%	±12%
	100	C	SVZC1A107M	10	10	125	18	12	±12%	±12%
	100	V	SVZV1A107M	10	8	150	18	10	±12%	±12%
	100	D	SVZD1A107M	10	8	100	18	10	± 5%	± 5%
	150	V	SVZV1A157M	15	8	150	14	10	±12%	±12%
	150	D	SVZD1A157M	15	10	100	18	12	±12%	±12%
	220	D	SVZD1A227M	22	12	100	22	14	±12%	±12%
16	47	D	SVZD1C476M	7.5	6	150	10	8	± 5%	± 5%
	68	C	SVZC1C686M	10.8	6	200	16	10	±12%	±12%
	68	D	SVZD1C686M	10.8	6	150	10	8	± 5%	± 5%
	100	D	SVZD1C107M	16	8	100	18	10	±12%	±12%
20	33	D	SVZD1D336M	6.6	6	200	10	8	± 5%	± 5%
	47	D	SVZD1D476M	9.4	6	150	10	8	± 5%	± 5%
25	6.8	C	SVZC1E685M	1.7	6	600	10	8	± 5%	± 5%
	15	D	SVZD1E156M	3.7	6	250	10	8	± 5%	± 5%
	22	D	SVZD1E226M	5.5	6	200	10	8	± 5%	± 5%
35	6.8	C	SVZC1V685M	2.3	6	600	10	8	± 5%	± 5%
	10	D	SVZD1V106M	3.5	6	300	10	8	± 5%	± 5%
	15	D	SVZD1V156M	5.2	6	300	10	8	± 5%	± 5%